

STD 316SS BUTT WELD FLANGE
 YIELD STRENGTH 205 MPa [30000 psi]
 TENSILE STRENGTH 515 MPa [75000 psi]

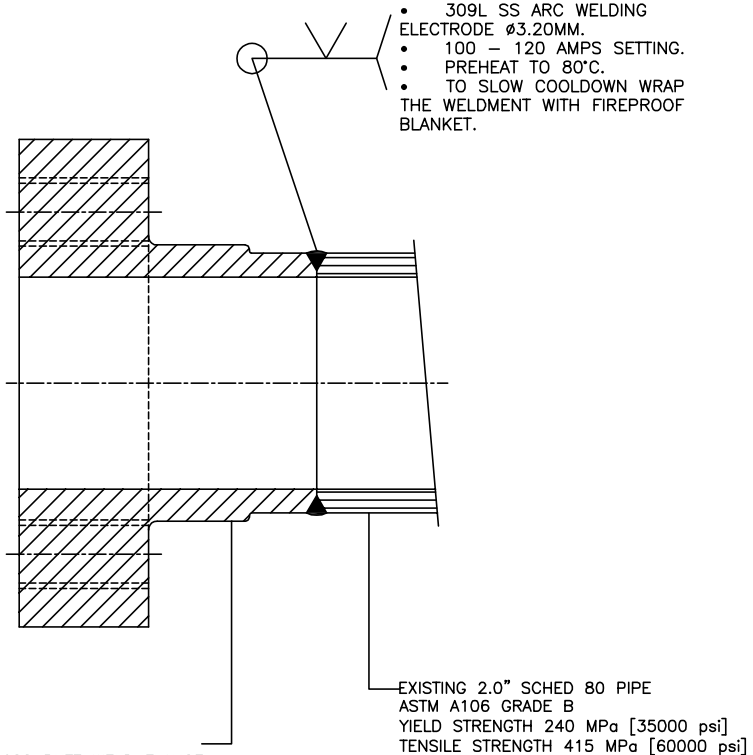

DETAIL C
 SCALE 1:1

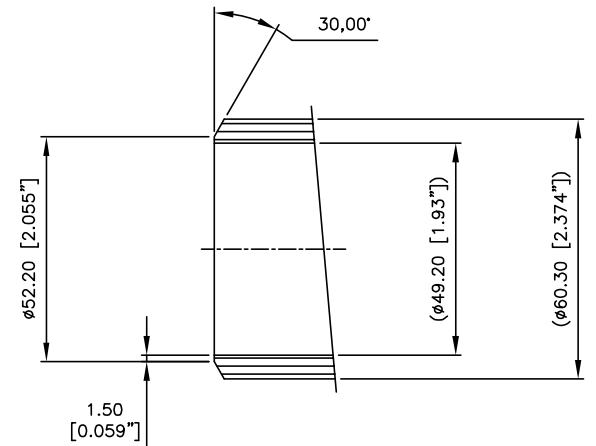

NOTES:

- EXISTING STEEL PIPE LINE TO SS FLANGE WELDMENT
- 316 SS BUTT WELD FLANGE: 1, 1/2" SAE CODE 62 x 2.0" SCHED 80 PIPE - 'ALFA' S2FVP2432
- PIPE: EXISTING 2.0" SCHED 80 PIPE

64 AUDLEY STREET
 WOODVILLE NORTH
 SA 5012 AUSTRALIA
 Ph : 08 8347 1700

HYDROL
 HYDRAULIC SERVICE

Project Number
 144276

PEA 46P 46A LUB

No.	OFF	MARK	No.	DESCRIPTION	MATERIAL	ISSUANT	REMARKS	SIP SERIAL NUMBER
I		COL.				DATE : 19/10/2023	SCALE :	
						NAME	SIGNATURE	
						DRAWN	JW	
						CHECKED	DH	
						REVIEWED	PD	
						REV. NUMBER		
								144276

64 AUDLEY STREET
 WOODVILLE NORTH
 SA 5012 AUSTRALIA
 Ph : 08 8347 1700

HYDROL
 HYDRAULIC SERVICE

92813395 NOTIF.
 CAD. REF. :